



STATE OF NORTH CAROLINA
DEPARTMENT OF TRANSPORTATION

PAT MCCRORY
GOVERNOR

ANTHONY J. TATA
SECRETARY

October 7, 2014

Addendum No. 2

Contract No.: 11421568

TIP No.: N/A

WBS No.: 1SP.10371.4, ETC.

Construction of Secondary Containment Structures in Gates, Hertford and Hyde Counties

To Whom It May Concern:

Reference is made to the proposal and plans previously furnished for this project.

The following revision has been made to the proposal and plans:

Page No. 1, "Proposal Cover" has been revised changing the Bid Opening Date from **October 8, 2014** to **October 15, 2014**. Please void existing Page No. 1 and staple revised Page No. 1 thereto.

Page No. 4, "Instruction to Bidders" has been revised changing the Bid Opening Date from **October 8, 2014** to **October 15, 2014**. Please void existing Page No. 4 and staple revised Page No. 4 thereto.

Page No. 6, "Intermediate Contract Time Number 2 and Liquidated Damages" has been revised changing the Completion Date from **December 5, 2014** to **December 12, 2014**. Please void existing Page No. 6 and staple revised Page No. 6 thereto.

Plan Sheets have been revised to change the "Wall Control Joint Detail" from a cold joint to a continuous pour with chamfered joint. Please void existing Plan Sheets and staple revised Plan Sheets thereto.

Please acknowledge receipt of Addendum #2 in the space provided on the Addendum Acknowledgement Form.

Sincerely,
DocuSigned by:

Handwritten signature of W. B. Hobbs in black ink.

99A5A272ED6A447...
W. B. Hobbs, PE

Division Project Manager

WBH
Attachment

cc: S. D. Baker, PE
C. S. Mebane, PE
R. L. Shook

STATE OF NORTH CAROLINA
DEPARTMENT OF TRANSPORTATION
HIGHWAY DIVISION 1

REVISED 10/7/2014

PROPOSAL

DATE AND TIME OF BID OPENING: OCTOBER 15, 2014 AT 2:00 PM

CONTRACT ID: 11421568

WBS ELEMENT NO.: 1SP.10371.4, ETC.

COUNTY: GATES, HERTFORD AND HYDE COUNTIES

**LOCATION: SECONDARY CONTAINMENT STRUCTURE AT GATESVILLE,
UNION, & SWAN QUARTER MAINTENANCE YARDS**

TYPE OF WORK: CONSTRUCT SECONDARY CONTAINMENT STRUCTURES

NOTICE:

ALL BIDDERS SHALL COMPLY WITH ALL APPLICABLE LAWS REGULATING THE PRACTICE OF GENERAL CONTRACTING AS CONTAINED IN CHAPTER 87 OF THE GENERAL STATUTES OF NORTH CAROLINA WHICH REQUIRES THE BIDDER TO BE LICENSED BY THE N.C. LICENSING BOARD FOR CONTRACTORS WHEN BIDDING ON ANY NON-FEDERAL AID PROJECT WHERE THE BID IS \$30,000 OR MORE, EXCEPT FOR CERTAIN SPECIALTY WORK AS DETERMINED BY THE LICENSING BOARD. BIDDERS SHALL ALSO COMPLY WITH ALL OTHER APPLICABLE LAWS REGULATING THE PRACTICES OF ELECTRICAL, PLUMBING, HEATING AND AIR CONDITIONING AND REFRIGERATION CONTRACTING AS CONTAINED IN CHAPTER 87 OF THE GENERAL STATUTES OF NORTH CAROLINA. NOTWITHSTANDING THESE LIMITATIONS ON BIDDING, THE BIDDER WHO IS AWARDED ANY FEDERAL - AID FUNDED PROJECT SHALL COMPLY WITH CHAPTER 87 OF THE GENERAL STATUTES OF NORTH CAROLINA FOR LICENSING REQUIREMENTS WITHIN 60 CALENDAR DAYS OF BID OPENING.

THIS IS A DIVISION LET PROJECT.

BID BOND NOT REQUIRED.

NAME OF BIDDER

ADDRESS OF BIDDER

INSTRUCTIONS TO BIDDERS REVISED 10/7/2014**PLEASE READ ALL INSTRUCTIONS CAREFULLY
BEFORE PREPARING AND SUBMITTING YOUR BID.**

All bids shall be prepared and submitted in accordance with the following requirements. Failure to comply with any requirement shall cause the bid to be considered irregular and shall be grounds for rejection of the bid.

1. The bid sheet furnished by NCDOT with the proposal shall be used and shall not be altered in any manner. **DO NOT SEPARATE THE BID SHEET FROM THE PROPOSAL!**
2. All entries on the bid sheet, including signatures, shall be written in ink.
3. The Bidder shall submit a unit price for every item on the bid form. The unit prices for the various contract items shall be written in figures. *****Unit Prices need to be limited to TWO decimal places.*****
4. An amount bid shall be entered on the bid sheet for every item. The amount bid for each item shall be determined by multiplying each unit bid by the quantity for that item, and shall be written in figures in the "Amount Bid" column of the sheet.
5. The total amount bid shall be written in figures in the proper place on the bid sheet. The total amount shall be determined by adding the amounts bid for each item.
6. Changes in any entry shall be made by marking through the entry in ink and making the correct entry adjacent thereto in ink. A representative of the Bidder shall initial the change in ink.
7. The bid shall be properly executed. All bids shall show the following information:
 - a. Name of individual, firm, corporation, partnership, or joint venture submitting bid.
 - b. Name and signature of individual or representative submitting bid and position or title.
 - c. Name, signature, and position or title of witness.
 - d. Federal Identification Number (or Social Security Number of Individual)
 - e. Contractor's License Number (if Applicable)
8. Bids submitted by corporations shall bear the seal of the corporation.
9. The bid shall not contain any unauthorized additions, deletions, or conditional bids.
10. The bidder shall not add any provision reserving the right to accept or reject an award, or to enter into a contract pursuant to an award.
11. **THE PROPOSAL WITH THE BID FORM STILL ATTACHED SHALL BE PLACED IN A SEALED ENVELOPE AND SHALL HAVE BEEN DELIVERED TO AND RECEIVED IN THE NCDOT DIV. ONE OFFICE, 113 AIRPORT DRIVE, SUITE 100, EDENTON, NC 27932 LOCATED APPROXIMATELY 5 MILES SOUTHEAST OF EDENTON, JUST OFF NC 94 ON AIRPORT DRIVE IN THE NORTHEASTERN REGIONAL AIRPORT BUILDING, BY 2:00 P.M. ON, WEDNESDAY, OCTOBER 15, 2014.**
12. The sealed bid must display the following statement on the front of the sealed envelope:

QUOTATION FOR 11421568 – CONSTRUCTION OF SECONDARY CONTAINMENT STRUCTURE IN GATES, HERTFORD AND HYDE COUNTIES TO BE OPENED AT 2:00 P.M. ON OCTOBER 15, 2014

13. If delivered by mail, the sealed envelope shall be placed in another sealed envelope and the outer envelope shall be addressed as follows:

**N. C. DEPARTMENT OF TRANSPORTATION
ATTN: Barry Hobbs, PE
113 Airport Drive, Suite 100
Edenton, NC 27932**

AWARD OF CONTRACT

The award of the contract, if it be awarded, will be made to the lowest responsible Bidder in accordance with Section 102, (excluding section 102-10) of the 2012 Standard Specifications for Roads and Structures. The lowest responsible Bidder will be notified that his bid has been accepted and that he has been awarded the contract. NCDOT reserves the right to reject all bids

before sunset the Thursday before Independence Day and 30 minutes after sunrise the Tuesday after Independence Day.

6. For **Labor Day**, between the hours of 30 minutes before sunset Friday and 30 minutes after sunrise Tuesday.
7. For **Thanksgiving Day**, between the hours of 30 minutes before sunset Tuesday and 30 minutes after sunrise Monday.
8. For **Christmas**, between the hours of 30 minutes before sunset the Friday **before the week of Christmas Day** and 30 minutes after sunrise the following Monday **after the week of Christmas Day**.

Holidays and holiday weekends shall include New Year's, Easter, Memorial Day, Independence Day, Labor Day, Thanksgiving, and Christmas. The Contractor shall schedule his work so that lane closures are not required during these periods, unless otherwise directed by the Engineer.

The time of availability for this intermediate contract work shall be the time the Contractor begins to install all traffic control devices for lane closures according to the time restrictions listed herein.

The completion time for this intermediate contract work shall be the time the Contractor is required to complete the removal of all traffic control devices for lane closures according to the time restrictions stated above and place traffic in the existing traffic pattern.

The liquidated damages are **Two Hundred Fifty Dollars (\$250.00)** per hour time period or any portion thereof.

INTERMEDIATE CONTRACT TIME NUMBER 2 AND LIQUIDATED DAMAGES:

(2-20-07)

108

SP1 G14 C

The Contractor shall complete all of the required work of constructing the secondary containment structure at the Swan Quarter Maintenance Yard, located in Hyde County.

The time of availability for this intermediate contract time will be When the Purchase Order is Issued.

The completion time for this intermediate contract time will be December 12, 2014.

The liquidated damages are **Two Hundred and Fifty Dollars (\$250.00)** per calendar day.

REVISED: 10/7/2014

GATES COUNTY MAINTENANCE YARD
304 US 158 W
Gatesville, NC 27938



NOTE: VERIFY WATERSTOP CHOSEN IS COMPATIBLE W/ BRINE SOLUTION

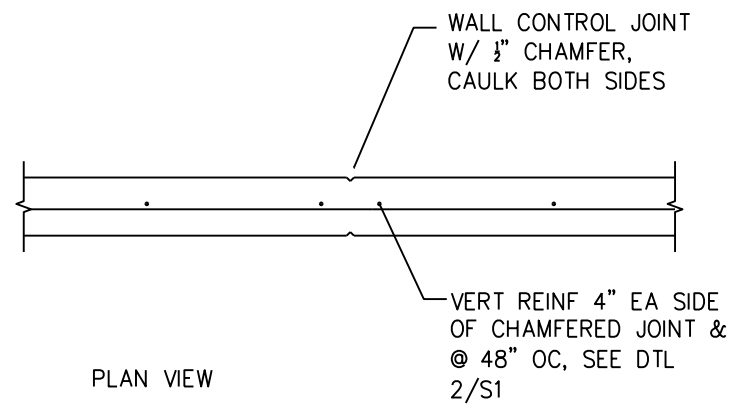

PLAN VIEW

3 WALL CONTROL JOINT
S1 SCALE: 1" = 2'-0"

1. CONCRETE SHALL HAVE MAXIMUM W/C RATIO = 0.40 & MIN COMPRESSIVE STRENGTH = 5000 PSI. CONCRETE FOR SLABS & WALLS SHALL BE AIR ENTRAINED.
2. ALL REINF STEEL SHALL BE ASTM A 615, GR 60.
3. CJ DENOTES SAWN SLAB CONTROL JOINT. SEAL CONTROL JOINTS.
4. WCJ DENOTES WALL CONTROL JOINT. SEE DETAIL 3/S1.
5. SLOPE SLAB MIN 1/4" / FT TO DRAIN VALVE(S).

6" CONC SLAB REINF W/ EPOXY COATED #4 @ 12" EW ON 6" COMPACTED GRANULAR BASE (GRADING AND STONE WORK TO BE PERFORMED BY NCDOT) NOTE: CONTRACTOR WILL BE RESPONSIBLE FOR EXCAVATION OF FOOTER LOCATIONS

HIGH POINT OF SLAB, ELEVATION VARIES BY SITE, FIELD VERIFY

CONTAINMENT WALL

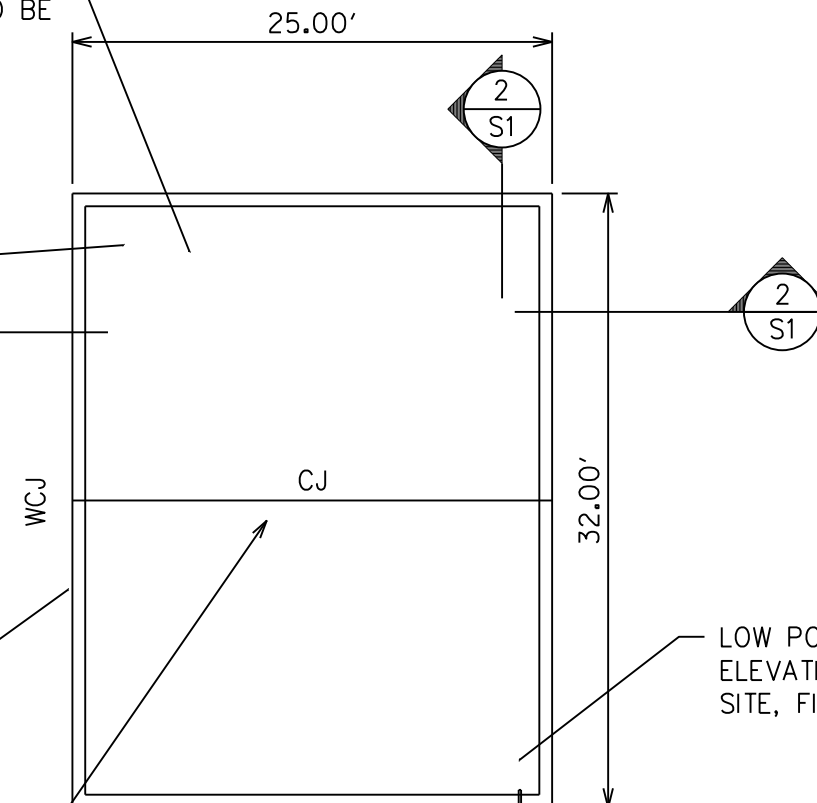

LOW POINT OF SLAB, ELEVATION VARIES BY SITE, FIELD VERIFY

2" DRAIN VALVE W/ LOCK AT LOW POINT OF SLAB, COORD LOCATION W/ OWNER

SPACE SLAB CONTROL JOINTS AT APPROX 16' OC & INSTALL WALL CONTROL JOINTS TO MATCH SLAB JOINTS.

ADJUST SLAB SLOPES FOR PROPER DRAINAGE

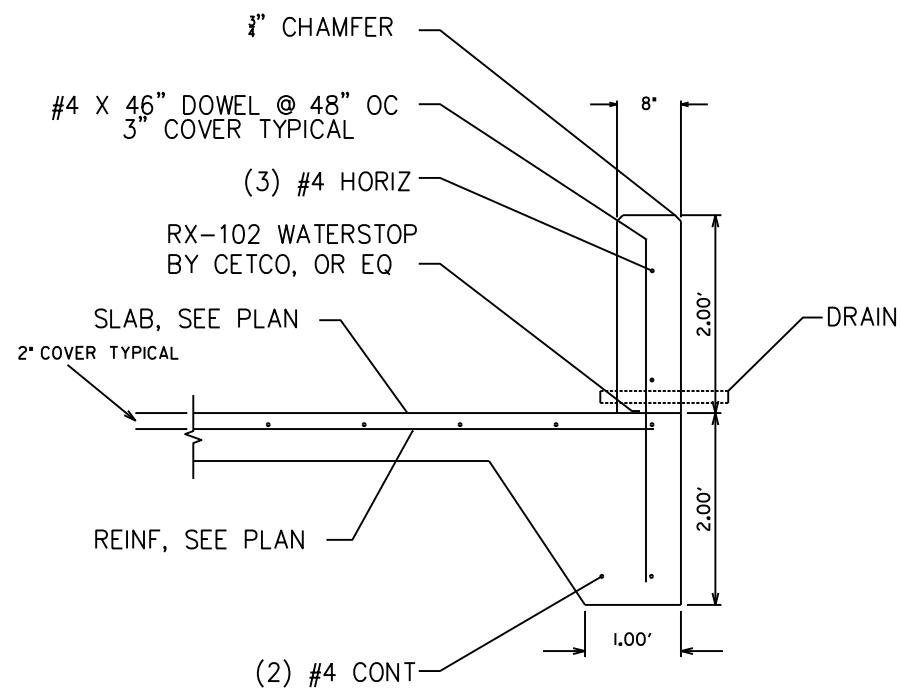

2 EXTERIOR SLAB EDGE
S1 SCALE: 1/2" = 1'-0"

1 FOUNDATION PLAN
S1 SCALE: 1" = 10'-0"

HYDE COUNTY MAINTENANCE YARD
 1245 MAIN STREET
 SWAN QUARTER, NC 27885



NOTE: VERIFY WATERSTOP CHOSEN IS COMPATIBLE W/ BRINE SOLUTION

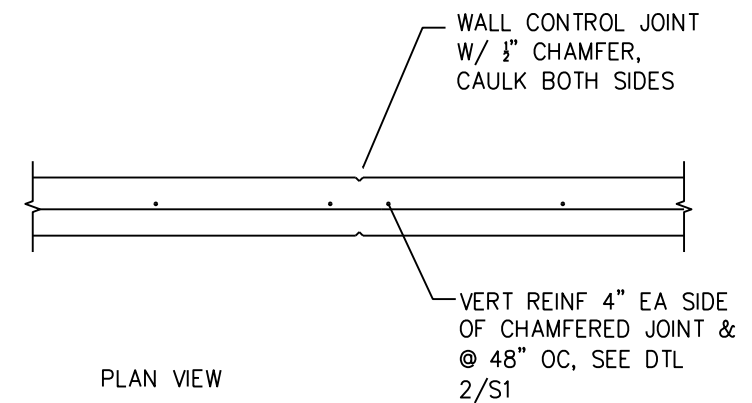

PLAN VIEW

3 WALL CONTROL JOINT
 S1 SCALE: 1" = 2'-0"

1. CONCRETE SHALL HAVE MAXIMUM W/C RATIO = 0.40 & MIN COMPRESSIVE STRENGTH = 5000 PSI. CONCRETE FOR SLABS & WALLS SHALL BE AIR ENTRAINED.
2. ALL REINF STEEL SHALL BE ASTM A 615, GR 60.
3. CJ DENOTES SAWN SLAB CONTROL JOINT. SEAL CONTROL JOINTS.
4. WCJ DENOTES WALL CONTROL JOINT. SEE DETAIL 3/S1.
5. SLOPE SLAB MIN 1/4" / FT TO DRAIN VALVE(S).

6" CONC SLAB REINF W/ EPOXY COATED #4 @ 12" EW ON 6" COMPACTED GRANULAR BASE
 (GRADING AND STONE WORK TO BE PERFORMED BY NCDOT)
 NOTE: CONTRACTOR WILL BE RESPONSIBLE FOR EXCAVATION OF FOOTER LOCATIONS

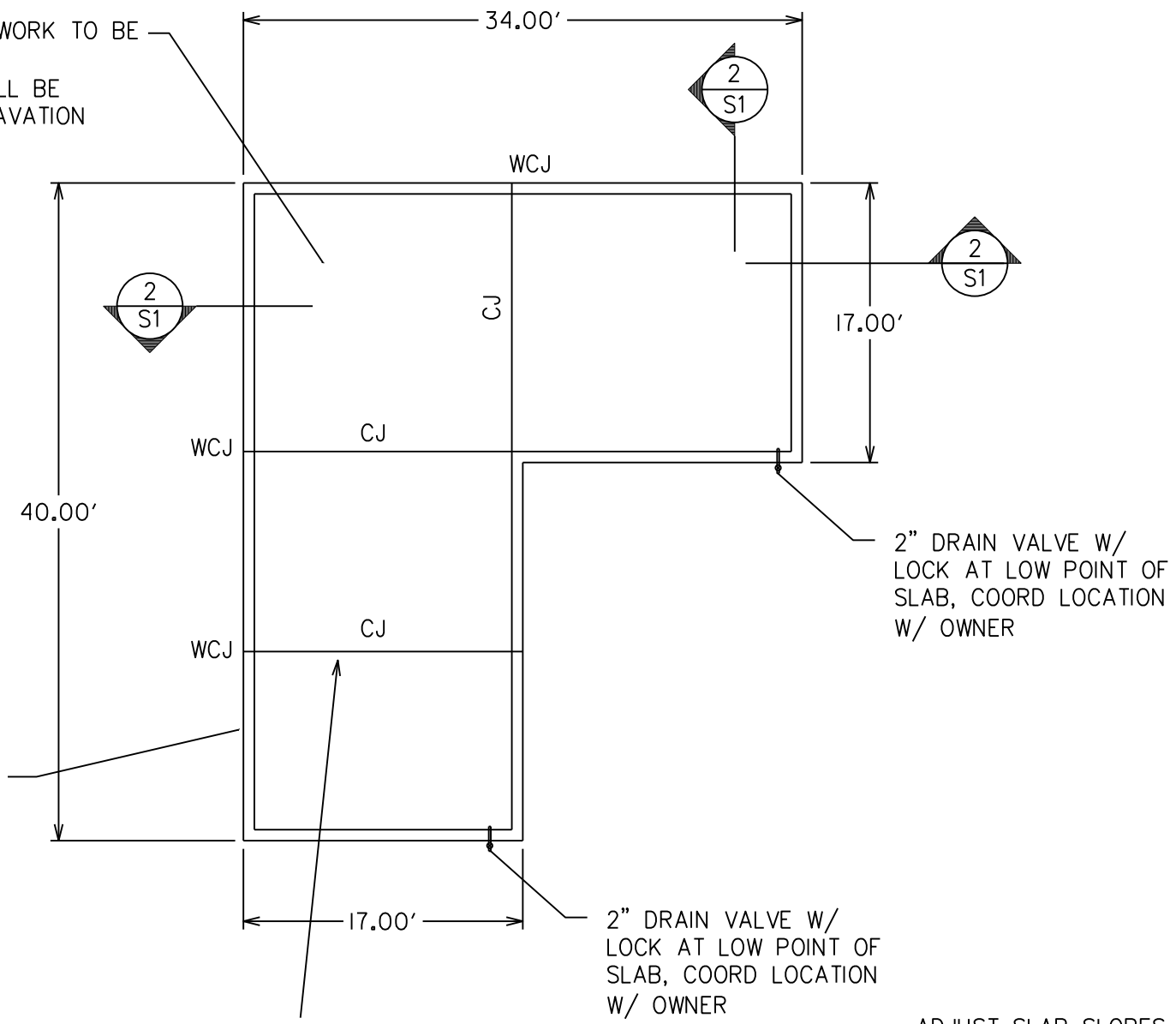

CONTAINMENT WALL

SPACE SLAB CONTROL JOINTS PER PLANS & INSTALL WALL CONTROL JOINTS TO MATCH SLAB JOINTS.

ADJUST SLAB SLOPES FOR PROPER DRAINAGE

1 FOUNDATION PLAN
 S1 SCALE: 1" = 10'-0"

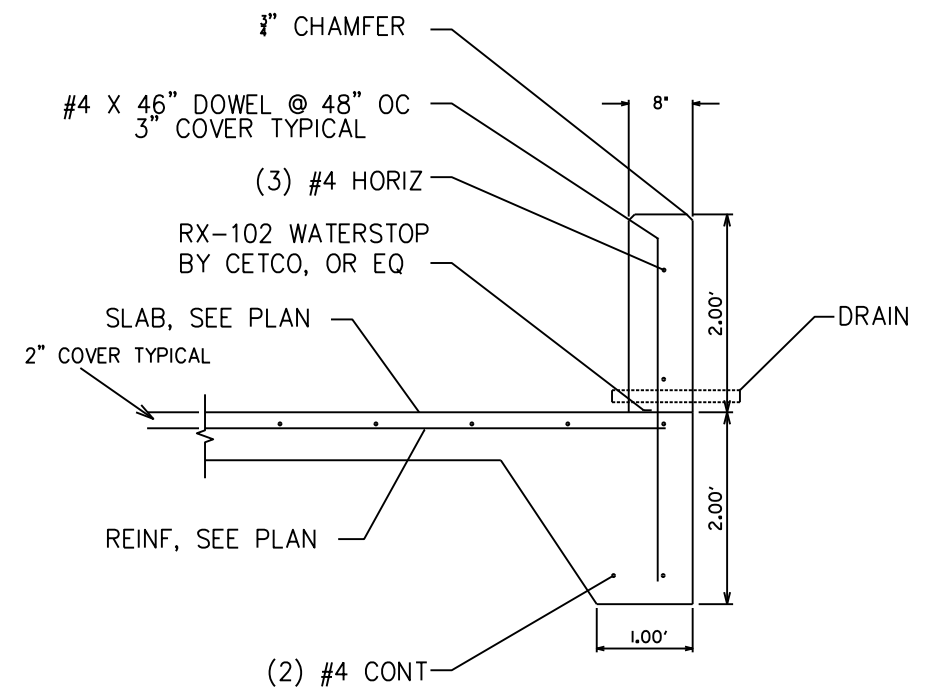

2 EXTERIOR SLAB EDGE
 S1 SCALE: 1" = 2'-0"

HERTFORD COUNTY MAINTENANCE YARD
318 W. MODLIN RD
AHOSKIE, NC 27910

NOTE: VERIFY WATERSTOP CHOSEN
IS COMPATIBLE W/ BRINE SOLUTION

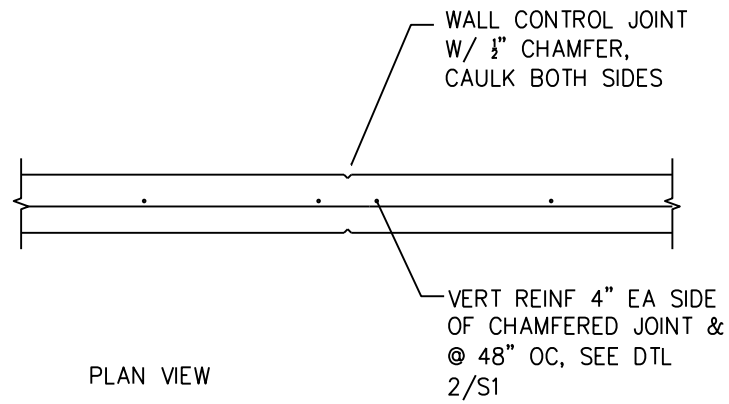

3 WALL CONTROL JOINT
S1 SCALE: 1" = 2'-0"

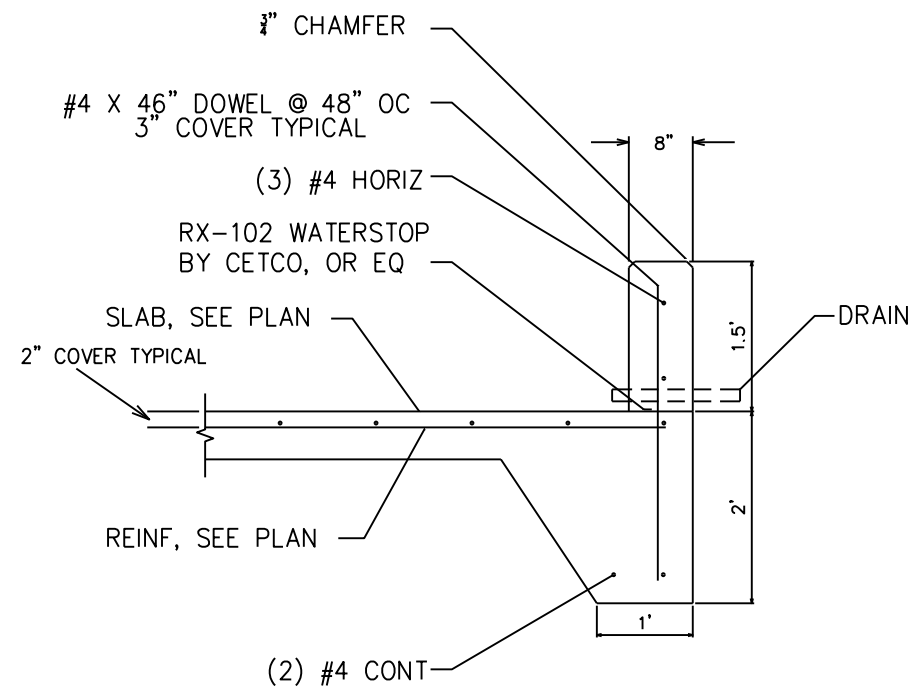

2 EXTERIOR SLAB EDGE
S1 SCALE: 1" = 2'-0"